



# SWERA

**Solar and Wind Energy Resource Assessment**

## **Short Training Course in SOLAR Radiation Assessment**

National Institute for Spacial Researches - INPE  
Solar Energy Laboratory of the  
Federal University of Santa Catarina - LABSOLAR / UFSC

# Short Training Course in SOLAR Radiation Assessment of SWERA

Recife – Brazil on May 25, 2002

Authors:

Enio B. Pereira INPE  
Felix Zamorano Banda INPE  
Fernando Ramos Martins INPE  
Samuel L. Abreu LABSOLAR  
Sylvio L. Mantelli Netto INPE/LABOSLAR

## Introduction

Interest in solar radiation has increased substantially in the last two decades for economic reasons, particularly after the oil crisis of 1973, when it got a major boost in Europe and United States as an alternate source of energy to fossil fuels. Today, this interest has an even greater importance that encompasses not only its application as a source of clean and renewable energy but also a crucial knowledge of the climate, its changes and issues dealing with life preservation on planet earth. As a result of this situation the SWERA (Solar and Wind Energy Resource Assessment) project arose. It is a multinational project financed by UNEP (United Nations Environmental Program) aimed at performing a detailed survey of solar and wind resources of various developing countries employing the most modern techniques presently available. In order to better achieve this goal, an informative and basic training was given in Recife – Brazil on May 25, 2002 on obtaining data about solar radiation on surfaces and through the usage of artificial satellites.

This report's goal is to complement what was presented during the training session and to furnish practical and informative knowledge to people in the technical area of the SWERA project of participating countries in Latin America. The matter covered herein is far from covering all of the important technical aspects needed for a good data base on solar radiation, but represents a first step for such.

## Background

Global climactic changes occurred in the last decades motivated a series of questions that indicate a global heating due primarily to the greenhouse effect, caused by the emission of gases acting like barriers to thermal radiation emitted by the planet. Emission of these gases is a direct consequence of the energetic needs of the population and it is growing with the increase of *per capita* energy consumption. There are, therefore, two alternatives to decrease this problem: reduction in the consumption of energy; substitution of traditional forms of energy for renewable ones.

On the other hand, the Sun is the main source of energy for the planet and all other sources are directly or indirectly related to it. Therefore, it becomes necessary to carefully analyze the potential of the solar energy available and what may be done to maximize its utilization.

The utilization of solar energy to diminish the consumption of energy in general implies in improving the performance of active and passive systems in which solar energy presents

itself as one of the regulating factors of the amount of energy spent. In the case of active systems, the knowledge of the solar potential helps in correctly sizing the installations, preventing wastes caused by oversize of equipment or inadequate performance caused by its under size. As for passive systems, natural lighting and the thermal conditioning of buildings stand out, where increasingly solar energy is being used to make buildings energetically more efficient, both during their design phase and after having been occupied.

To replace traditional forms of energy with solar energy it will be necessary to make it economically attractive. A contributing factor for this is the growing increase in cost of other sources of energy and the decline in cost of solar energy systems, both for heat and for electricity generation.

For heat generation, solar systems are becoming economically viable for various applications, mainly those in which electric or gas complement it for heating water. In most developed countries, large-scale use of this type of application is a reality already. The popularization of solar energy use in developing countries will depend on the availability of adequate information about its impact on energy savings. This could serve as subsidy for national incentive policies towards the utilization of solar energy.

The generation of electric energy from solar has been touted as a potential future market for large investments. The appearance of new technologies, including new processes and new materials to manufacture photovoltaic cells, has motivated cost reductions and, consequently, the appearance of new applications for which the economic viability is being achieved already. In the case of thermo-solar plants for electric energy generation, their efficiency already has been demonstrated and their cost will be competitive with plants utilizing fossil fuels in a very near future. Its applicability, however, is limited to regions with high insolation.

The trend for upcoming years suggests large investments in the area of solar energy and its large-scale applications. Such investments demand more reliable information and simulation tools not only for the performance of systems to be installed, but also for questions raised by the variability in solar resources and uncertainties about the methods of obtaining such data. Such information will permit investors to better evaluate financial risks involved. High financial risks cause options to go for more conservative forms of investment such as the conventional forms of energy.

It is also important to work with a diversified energetic matrix that allows for better administration of the energy resources of a country. In this way the forecast for a shortage of a certain energetic source for a certain period of time may be managed with the supply of another one until the former normalizes its supply. The greater the level of knowledge about the solar potential, the greater will also be the safety in planning for its use in parallel with other existing resources. This would allow verifying its ability to complement other forms and avoid the need to increase capacity for generation plants already installed.

The arguments presented justify the need for a detailed investigation of the potential usage of solar energy through the SWERA project. The mapping of solar resources from satellite images diminishes the surveying costs because it decreases its dependence on ground stations and insures that there will be fewer uncertainties as would be the case when interpolating data between surface stations. Even so, some surface stations are necessary to supply quality-measured data which will be utilized for validation and improvement of the estimating models using satellite images.

## Products of the project

### *Irradiation maps*

The solar irradiation maps will be calculated from satellite images of geo-stationary satellites (GOES, METEOSAT) utilizing different models for the computation of the incidence of solar radiation on the surface of the Earth. In figures 1 and 2 some results obtained for Brazil and the central and north Americas are presented. In addition to global solar irradiation maps, maps of direct and diffused components will also be generated as well as irradiation values for tilted surfaces. All of these will be validated utilizing the surface database of several existing solarimetric stations. Climactic data constitute entry parameters for models and will be obtained from a detailed revision of all available sources in each participating country.

To compare results of different models of satellites a mission of inter-comparison utilizing data from a solarimetric reference station installed by the SWERA project in Caicó – Brazil will be used.

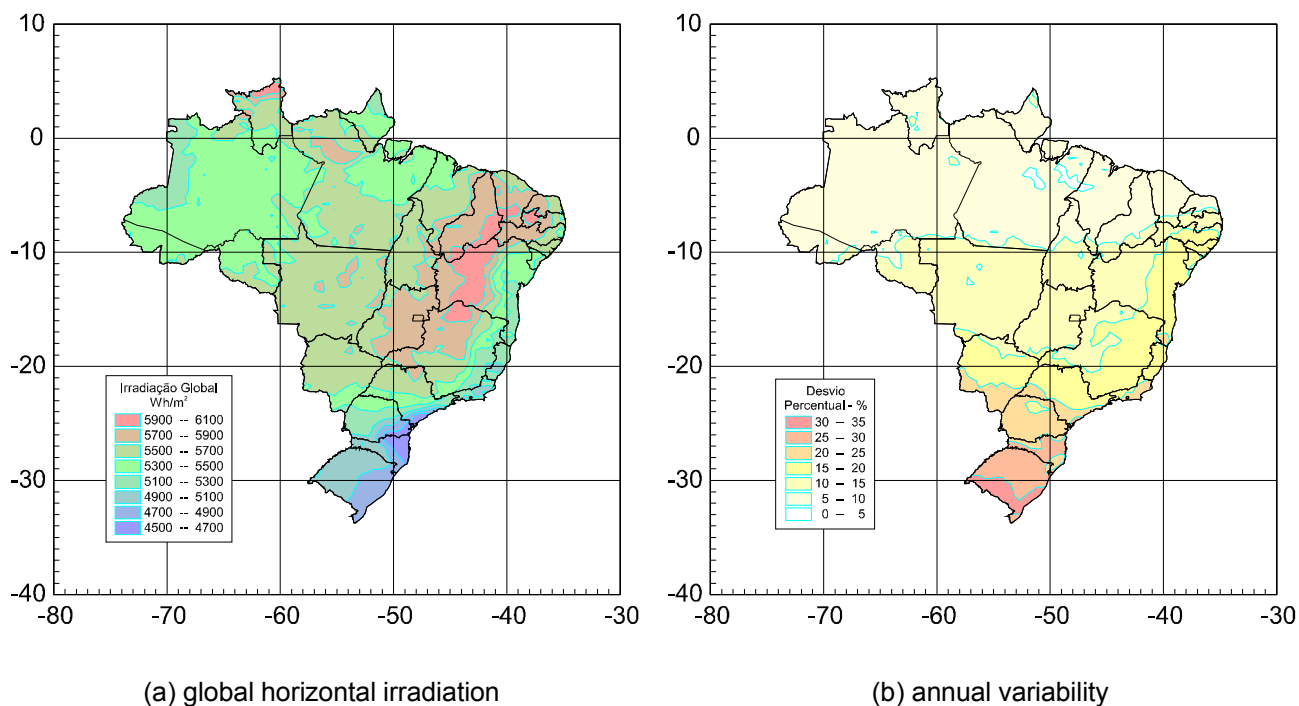

**Figure 1.** Annual historical average of totals of daily solar radiation incidence on the surface for Brazil.

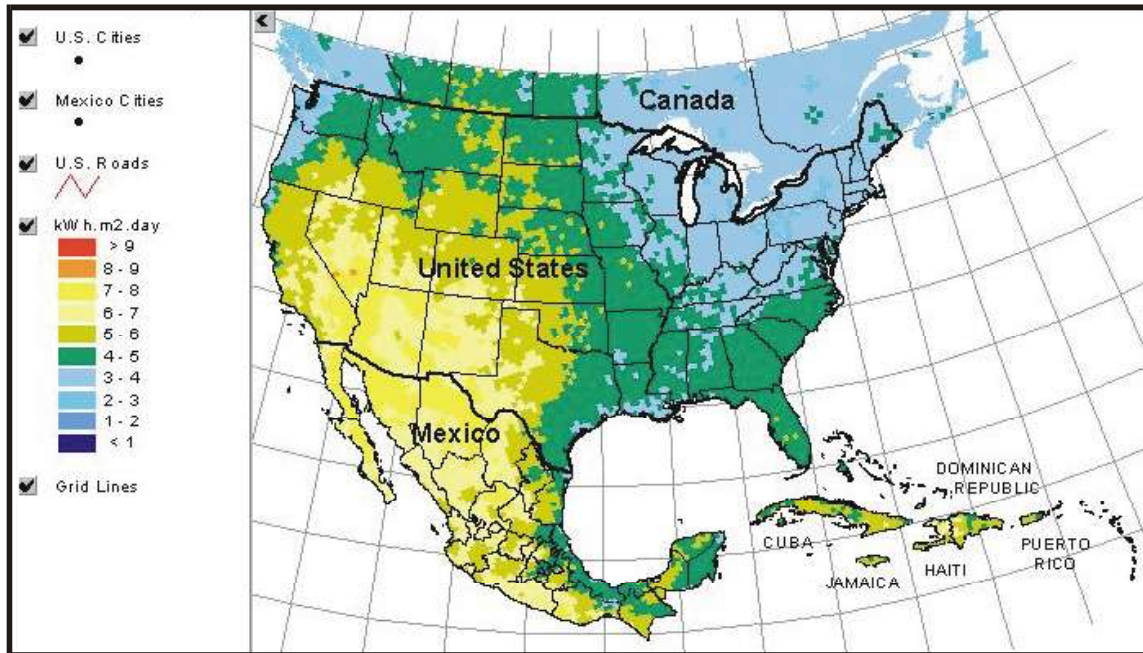

**Figure 2.** Annual historical total of daily direct solar normal radiation incidence on the surface for the USA, Mexico and Caribbean countries. Source: [www.nrel.gov](http://www.nrel.gov)

### **Generation of time series**

In various situations, only the monthly averages of daily totals may not be sufficient to obtain the desired results in the proposed application, therefore, hourly series of irradiation data will be generated for a few selected points. These series, known as TMY's (Typical Meteorological Year), will be developed in partnership with NREL (National Renewable Energy Laboratory). Long-term series of surface data supplied by NREL will be associated with short-term series of satellite images, thus creating the possibility to generate TMY's for any location.

### **Construction of different solar energy utilization scenarios**

Another product of the SWERA project is the construction of different scenarios for solar energy utilization, which will work as tools to be frequently employed in divulging products of the project and as a way of supplying the subsidies necessary for the large scale utilization of this type of energy. At this stage a cross-reference of information will be made about the solar resource with other socio-economic information available in the database of geographical information systems (GIS) of each country. It will also be necessary to develop methodologies to retrieve useful information for devising incentive policies for solar energy usage from the proposed information cross-reference.

### **Availability of results in various types of media**

The products of the SWERA project will be documented during the course of the project, and a few subjects will be selected for presentation in a more detailed form. This documentation, which will be made available to the general public, will consist of:

- A theoretic basis of the model utilized for estimating solar radiation including the methodology to calculate it and other information related to the ancillary databanks that were used.
- An Atlas of solar radiation showing maps of average monthly and yearly values of the various components of solar radiation, statistics maps of the variability of the solar resource and all the methodology for validation of the results using data obtained from surface measurements. The values of TMYs for the chosen localities and the methodology to obtain these values for any place shall also be detailed in the Atlas.
- The multimedia CDs that will accompany the printed results will include information in numeric form to allow for later utilization of solar radiation data by the users.
- A site on the Internet will make available the information about the development of the project as the data is being generated.

## **Applications for SWERA products**

The field for applying the products of SWERA is very large. Some of these applications were selected for a quick explanation about where the products of SWERA may be used and to give a general view of its current status.

### ***Energy generation***

The principal methods for generating electric power from solar energy are the photovoltaic and the thermo-solar generation systems. In both cases, they are technologies already mastered, but their installation costs are still high. One of the goals of SWERA is to make possible a reduction in the investment risk through the supply of a database of great reliability.

### ***Generation of photovoltaic electric energy***

This type of electric power generation had its first impulse in the aerospace industry, because just about all satellites have photovoltaic panels to capture and transform solar energy into electric power. With the passing of time new materials and new manufacturing techniques were developed and a new series of applications became viable. The most common applications nowadays are isolated or autonomous systems, interconnected systems connected to the utility grid and hybrid systems.

The autonomous systems generally are used for situations in which the demand for electric power is not very high and the costs to extend the utility grid are high. These systems have as a main feature the need for a cell bank to store energy and insure the supply at times when solar radiation is absent or is not enough to supply the demand.

The photovoltaic systems interconnected to the electric power distribution net are being more and more utilized thanks to government incentive programs of countries like Germany that offer the possibility for the owner of a photovoltaic system to become an independent

producer, who may sell the surplus energy of the photovoltaic panels to the company with the concession for the service at a higher price than what he pays that same company for the energy supplied. The forecast is that within a very near future this type of system may become viable without the subsidies currently being offered. This is the cheapest type of installation because it does away with the use of batteries and, by being connected to the utility grid, it avoids the need for it to have its capacity of generation and distribution expanded.

The hybrid systems are those in which several energetic alternatives are utilized together to insure the supply of energy whenever any of the sources fails. The hybrid installations may consist of photovoltaic systems, wind turbines, diesel generator sets, gas turbines, etc. The ideal configuration of the system will depend on the energetic resources available.

### ***Thermo-solar electric energy generation***

Thermo-solar electric energy generation may be done in two ways: the “solar farms” and the “solar towers”. A feature of this type of system is that it is applicable mainly in regions of very high insolation.

On the solar farms, the solar energy is harvested by groups of parabolic collectors that concentrate the irradiation over a tube through which water or oil circulates at temperatures of up to 520°C. The heat stored by the working fluid is used to generate steam to move a traditional turbine.

The solar towers are composed of a series of mirrors that track the movement of the Sun and reflect it on a fixed collector where the solar energy is absorbed and used to generate steam to move a turbine.

### ***Heating***

The use of solar energy to obtain heat currently is the most viable economic application of all forms of utilization of this energy. In general, the solar heat is utilized to heat air or water to temperatures that are not much higher than the surrounding environment, particularly for home use.

In case of heating water, the solar heating systems are composed of a group of collecting plates and an insulated reservoir. The basic principle of these systems is very simple: the heat absorbed by the collecting plates is transferred to the working fluid which then circulates through them to be stored in the insulated reservoir. These systems are utilized in single homes and apartment buildings.

In addition to residential heat, numerous other applications in the industrial sector may utilize solar energy. In the farming industry, for example, various situations exist in which wood or some other type of fuel is used to produce heat in situations where it would be perfectly possible to use solar energy.

### ***Refrigeration and Air conditioning***

Refrigeration cycles with ejectors or by absorption are viable for air conditioning by employing solar collectors as the source of heat. This type of technology is a natural candidate to

compete with the conventional refrigeration system, because generally, the greatest amount of solar energy available coincides with the greatest need to cool the environment.

### ***Thermal control of buildings***

The thermal conditions inside of buildings are greatly influenced by solar heat gains. The magnitude of these gains serves to evaluate how much can be used to passively heat in cold climates, or how much must be avoided in hot climates. In all computational models of simulations for buildings (DOE, ESPr, TAS, TRNSYS, etc.) the values of solar radiation are given as starting points and from their knowledge it is possible to obtain reliable results in simulations with few uncertainties.

### ***Agro-meteorology***

The use of solar energy as a fundamental entry variable in the study of agricultural crops is utilized in large scale, often empirically, because of a lack of awareness of more precise information about the availability of this resource. Reductions in yield due to the annual variation of solar radiation are responsible for financial losses of the peasants and these in turn cause fluctuations in international food prices that may bring economical benefits or damages to several countries.

The knowledge about solar energy in spectral band PAR (Photosynthetically Active Radiation) and the possibility to estimate it quickly, or even make forecasts with few uncertainties, may be decisive to increase crop productivity or the production of organic matter to be used in the generation of energy. The correct timing for planting and harvesting and the type of crop better suited for each region may be defined with the help of irradiation data and, in this way, minimize possible risks derived from negative effects that variations in irradiation may cause.

## **Measuring the Solar Radiation**

### ***Campbell-Stokes Sunshine Recorder***



This type of equipment is the most widely found in traditional meteorological stations. It distinguishes itself for its reliability, but only measures the number of insolation hours. To determine the solar radiation based on the number of hours of insolation, the Angström method is used.



## ***Pyranometer***



This is the most widely-used equipment to measure global solar radiation. There are different types of pyranometers, being the most common those which sensors are composed of thermopiles or photovoltaic cells. The photovoltaic sensors are in general much less precise than the thermopiles due to the fact that the spectral response is not the same in the entire solar radiation spectrum.

## ***Pyrheliometer***

This equipment is used to measure direct solar radiation. It works in a similar way as to the pyranometer, but a tube only allows that the direct solar radiation reaches the sensor. Since the position of the sun changes along the day, it is necessary to have a device which does the sun-tracking, that is, it always needs to be aligned with the sun. The pyrliometer is also utilized as a calibration reference of solar radiation sensors. The most knows types of pyrliometers are the following:

### ***Angström compensation Pyrliometer***



First instrument for precise direct solar radiation measurements (end of XIX century).

### ***Absolute cavity Pyrliometer***



Developed since the mid 60s. Current world reference for calibration of solar radiation sensors.

### *Field Pyrheliometer*

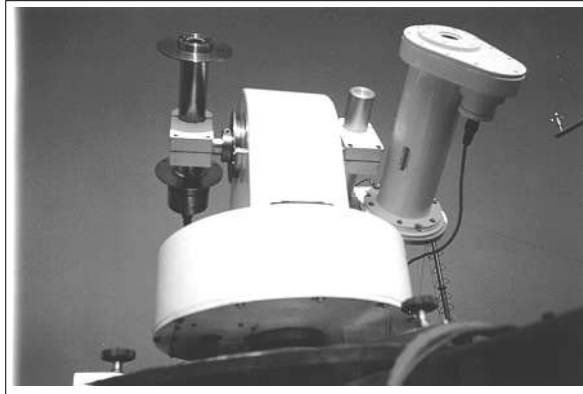

Used at solarimetric stations for direct solar radiation measurements, it has thermopile sensors.

### **Shaded Pyranometer**

Used to measure diffuse solar radiation. It needs a shading device so that the sensor cannot "see" the sun, thus allowing, in this way, that the radiation which comes directly from the sun not be measured.

#### *Pyranometer with shading ring*



Relatively inexpensive solution for diffuse solar radiation measurement. Data need to be corrected, because the ring partially obstructs the passage of diffuse radiation.

#### *Pyranometer with shading disc*

More expensive solution for diffuse solar radiation measurement. Measured data does not require correction, because the disc obstructs only the path of direct radiation. On the other hand, requires a sun-tracking device which can be of one or two axis.

### **Pirgeometer**



Used to measure long-wave radiation. It is utilized with or without shading to block the direct solar radiation. The protecting dome has filters to avoid the entrance of radiation of other wavelengths.

## Albedometer

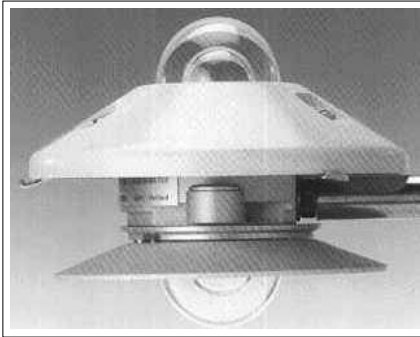

Albedo is the measurement which quantifies how much the medium (vegetation, buildings, mountains, soil, snow, etc.) reflects solar radiation which falls onto it. Its value is calculated by dividing the total solar radiation reflected by the medium by the global solar radiation incident at the location. The Albedometer is an equipment that measures both the global solar radiation as well as the reflected radiation, giving as an answer the albedo value. To assure a more precise measurement, it is generally installed several meters above the surface.

## Measuring the Ultraviolet Radiation

The electromagnetic radiation of  $\lambda$  wavelengths between the visible region of the spectrum and the X-rays, in vacuum, are called *ultraviolet radiation*(UV). The amount of corresponding solar energy of this spectral region is very small, of the order of 1.5% at the top of the earth's atmosphere, and it only 0.5% reaches the surface of the earth (Blumthaler, 1993). The band of wavelengths extends itself approximately from 10 nm up to 400 nm, which photons have energy between 3 and 120 eV respectively.

This band of wavelengths subdivides itself in other bands. A first subdivision considers five bands (Coulson, 1975) designated by:

*NUV* (Near Ultraviolet), region which extends from 400 up to 300 nm;

*MUV* (Middle Ultraviolet), which extends from 300 up to 200 nm;

*FUV* (Far Ultraviolet), which corresponds to the region from 200 up to 100 nm;

*VUV* (Vacuum Ultraviolet), which includes wavelengths between 200 and 10 nm;

*EUV* (Extreme Ultraviolet), sometimes abbreviated as XUV, which includes the region between 100 and 10 nm.

Another subdivision is related to the biological effects which radiation causes (Huffman, 1992), and which considers three regions between 100 and 400 nm. These three regions are:

*UV-A*, which corresponds to a band of wavelengths between 400 and 320 nm, which is not absorbed in a clean atmosphere and which reaches the surface of the earth;

*UV-B*, region between 320 and 280 nm. In this narrow band, the solar energy received at the surface of the earth per time unit (power) is only of 2 W/m<sup>2</sup> at 55° of latitude. This radiation is absorbed mainly by the ozone of the atmosphere;

*UV-C*, which corresponds to the region starting at 280 nm up to wavelengths of 100 nm and which is totally absorbed by the atmosphere.

In recent years, the interest in studies of UV radiation has concentrated itself on type UV-B radiation (280 to 320 nm), due to its relation with the harmful effects which it can produce in our biosphere (Roy et al., 1994), especially to human health (Tevini, 1993; Madronich, 1993). Within this context, the most widely mentioned in the literature is skin cancer, but also cataracts and the suppression of the immune system, which debilitates the defenses against infectious diseases (De Fabo et al., 1990; McKenzie et al., 1991; Cooper et al., 1992).

Figure 11 shows the attenuation of the solar radiation intensity through different components of the earth's atmosphere. Three curves can be observed: the less intense solid line which corresponds to the radiation not attenuated by the earth's atmosphere, and the intense solid line which corresponds to the radiation attenuated at sea level by different components of the atmosphere. Ozone, for example, attenuates in the narrow band of wavelengths around 300 nm. The dotted line corresponds to radiation of a black body at 5900 K, which is very similar to radiation emitted by the sun.

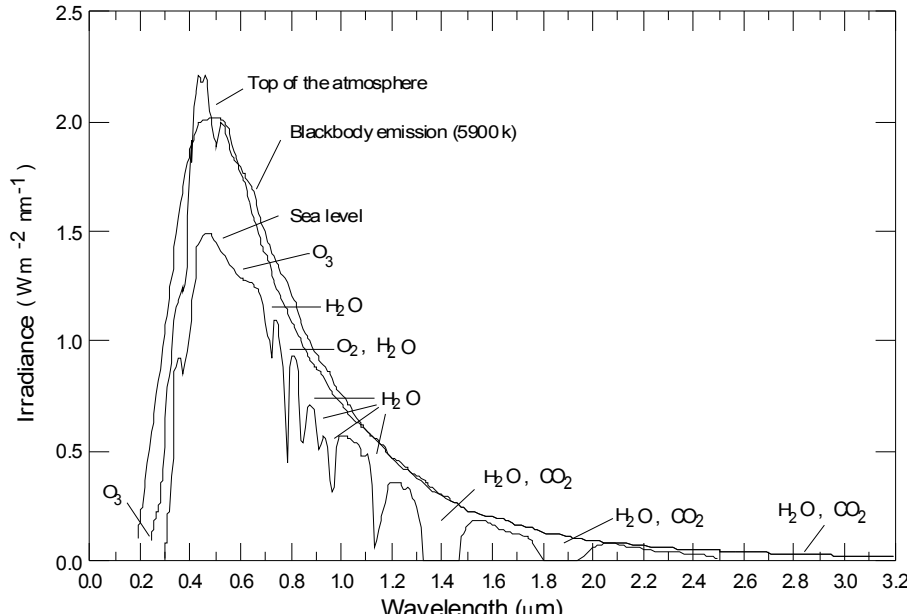

**Figure 11.** Radiation intensity as a function of wavelength: outside the earth's atmosphere and at sea level, absorbed by the indicated atmospheric species.

SOURCE: Handbook of Geophysics and Space Environments, McGraw-Hill, New York, 1965

There are two methods of measuring UV, which can be classified in chemical and physical. The chemical methods in the measurement of UV radiation were utilized between the 1920s and 1930s and are based on the quantitative measurement of the product of a chemical reaction. Some of the utilized instruments were the *dosimeter*, based on the change of color of certain materials when exposed to UV radiation and wavelengths  $\lambda < 310$  nm, the film *piranometer*, which consists of a film which optical density varies with the exposure to UV radiation around 400-410 nm and others, as for example, the photolysis of nitrogen dioxide and the optical degradation of plexiglass.

The physical measurement methods employ instruments or sensors, usually called radiometers, which are based on the principles of heat radiation, and also photomultipliers, photovoltaic cells, ionization chambers, or photographic film. One of the simplest is the Eppley radiometer, designed to measure continuously the UV radiation flux in the region included between 280 and 400 nm. The sensor has a photoelectric cell, a quartz diffuser and an interference filter. Manufactured to measure under various climatic conditions, the data collection is done by a computational system or a logger.

Another type of instrument is the UV-Biometer. This has a system with filters, which eliminates the visible light, and the partially filtered light excites a phosphorus component, which emits visible light that is detected by a photodiode and transformed in an electric pulse. It is calibrated in MED (Minimum Erythema Dosis), which is the minimum quantity of energy capable of causing an erythema, as defined previously.

Another radiometer, the GUV, has the capability of measuring UV in four wavelengths: 305, 320, 340 and 380 nm and, additionally, has a channel for measuring the photo-synthetically active radiation (PAR), in the band of 400 up to 700 nm. It works as an optical system that centers the flux that goes to the detector and transforms the information in an electrical pulse that is decoded and processed by micro-computer. The radiometer has a temperature control system, to avoid the dependence to it.

The more advanced instruments are the *high-resolution spectroradiometers*, which perform scans, through one of the wavelength bands (280 nm - 380 nm), determining the flux of UV in certain bands with excellent precision. One example of this type is the Brewer spectrophotometer, which does UV-B measurements by scans which start at 290 nm and go up to 320 nm, in 0.5 nm increments.

The Brewer optical system has a modified Ebert f/6 spectrometer with a diffraction grid of 1200 lines/mm. Two lamps, one mercury and the other halogen, incorporated to the system, allow the analysis of the light intensity and the instrument calibration.

The mentioned instruments are surface ones, that is, they are placed at appropriated places at ground level and measure the UV flux which reach them, but there are also instruments on board satellites such as high resolution spectroradiometers which measure the back-scattering radiation around the earth's atmosphere.

## Model utilization to obtain surface solar radiation estimates

When crossing the atmosphere, solar radiation suffers complex interactions of spreading and absorption by the atmospheric components and the planet's surface. Figure 1 represents, in a very simplified fashion, the main interaction processes of solar and thermal radiation within the Atmosphere-Earth system. The values shown refer to the mean global effect of all processes for each component of the radioactive balance of the planet and these may vary considerably from one region to the next and from one season to the next. (Harrison et al., 1993).

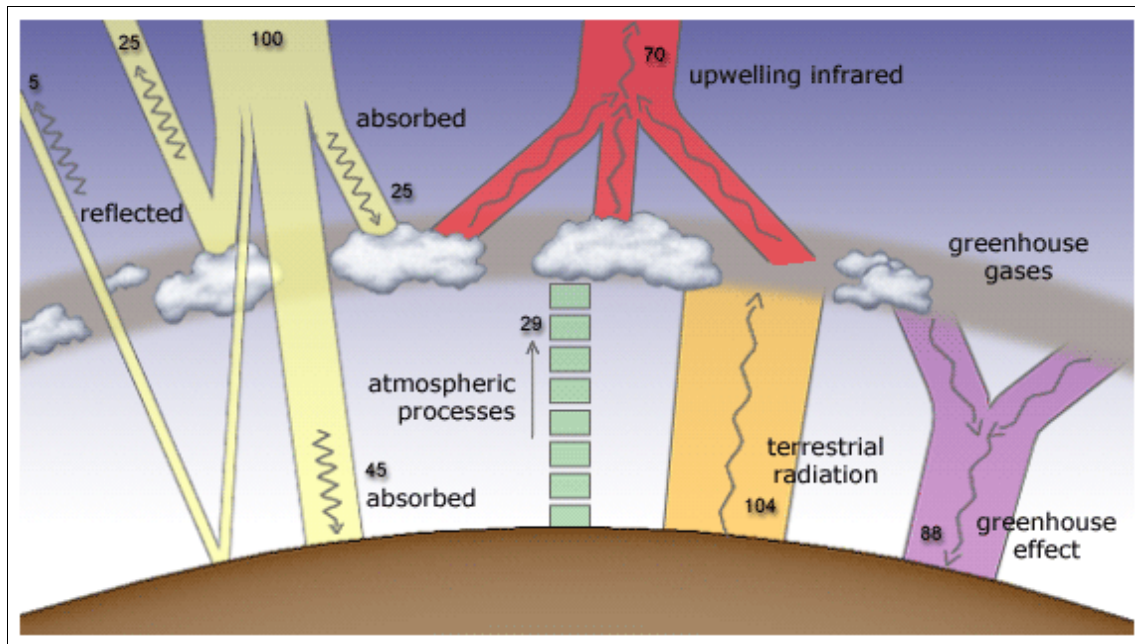

**Figure 12.** Symbolic diagram of interaction processes of solar radiation with earth's atmosphere. SOURCE: Gambi (1998).

Clouds, atmospheric gases and particles and surface reflect about 30% of radiation incidence on top of the atmosphere. The remaining 70% are absorbed, heating the system and causing water evaporation (latent heat) or convection (sensible heat). The energy absorbed by the Earth-Atmosphere system rebounds into the infrared spectrum of electromagnetic radiation – 4 to 100mm – of which 6% comes from the surface and 64% comes from clouds and atmospheric components.

Figure 13 presents the spectral intervals of radiation coming from the sun (short wave radiation or solar radiation) and emitted by the Earth-Atmosphere system (long wave radiation or thermal radiation). Figure 11 shows the electromagnetic spectrum of solar radiation that hits the top of the atmosphere and the planet's surface after attenuation in various wave lengths characterizing the processes of interaction that occur in the atmosphere. Figure 13 shows the electromagnetic spectrum of thermal radiation emitted by the Earth when seen from space at different altitudes.

Various computational models were developed to obtain solar radiation estimates reaching the surface (Stuhlmann, 1990; Diekmann et al., 1988, 1986; Pinker & Ewing, 1985; Gautier

et al., 1980; Tarpley, 1979; Kerschgens et al., 1978; Hay & Hanson, 1978; Raschke, 1972). These models may be classified into statistical models and physical models. The statistical models make use of empiric formulations between incident solar radiation measurements and local conditions, and, therefore provide restricted validity to the studied region and for the period of the year of validation. On the other hand, the physical models are valid for any region of the planet because they are based on the solution of the radiative transfer equation for the atmosphere. All radioactive processes that occur in the atmosphere are described mathematically by the radiative transfer equation. The parameterization of radiative processes depends on the knowledge of atmospheric data such as the cloud coverage and the profile of atmospheric constituents like aerosols, water vapor, ozone and other gases. The main modulating factor of solar radiation on the surface is the cloud coverage (Stuhlmann, 1990; Pinker & Laszlo, 1989b; Gautier et al., 1980).

Several techniques were developed to solve the radiative transfer equation in an exact way. Among them one may mention the methods that utilize spherical harmonics, discrete ordinates, successive orders of distribution, (Monte Carlo) and finite differentials (Dave e Canosa, 1974; Raschke, 1972; Lenoble, 1985). These techniques require an elevated computation time to obtain estimates for solar radiation, particularly in sky conditions with thick clouds (Kerschgens et al., 1978), making its routine application impractical. As an alternate to these exact techniques, approximate methods were developed requiring much less computation time for the purpose of obtaining reliable estimates of solar radiation in a routine operation. Among these estimated methods, the Two-Stream method stands out as one frequently used in current models (Lenoble, 1985, Martins, 2001).

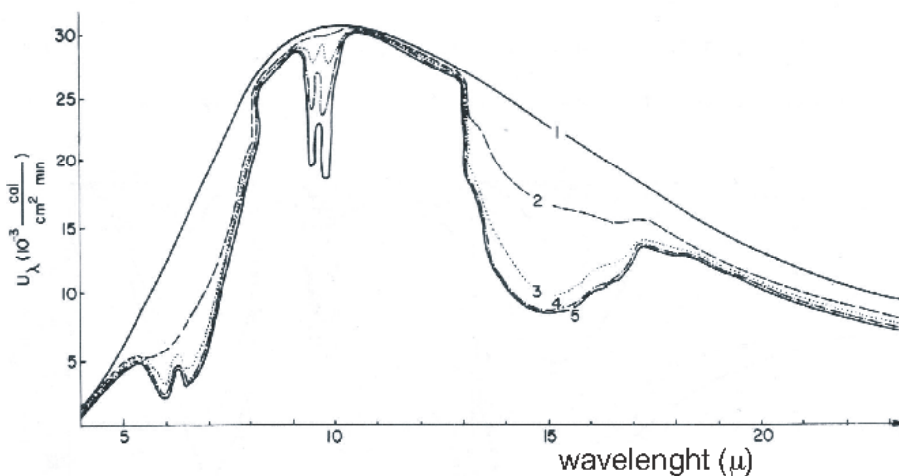

**Figure 13.** Spectrum of thermal solar radiation in 5 different altitudes: 1 - 100m, 2 - 4,6km, 3 - 10km, 4 - 18km e 5 - 28km. Source: Kondratyev (1969).

### Artificial Satellites

The major obstacle in applying physical models is the collecting of atmospheric data with the desired levels of precision and reliability (Raphael & Hay, 1984). The development of the remote sensing technology via artificial satellites allowed for great progress in the development of computational models. Satellite images are tools of great value in obtaining

the cloud coverage and other atmospheric parameters required for modeling radiative processes in the atmosphere. The first studies for the utilization of data obtained with satellites in estimating solar radiation reaching the surface were begun in the 1970s through the work of (Hanson, 1971; Vonder Haal, 1973; Vonder Haal & Ellis, 1975). These studies used orbital satellite data and, consequently, the cloud cover evaluation was very inaccurate because of their small time resolution (one image per day). Stationary satellites were being utilized at beginning of the 80s, and satellite data obtained with good time and space resolution (30 minutes and around 4 km at nadir) allowed a better evaluation of atmospheric parameters and consequently to get a more confident incident solar radiation estimates. (Gautier et al., 1980; Tarpley, 1979; Hay & Hanson, 1978).

There are various types of satellites in orbit around the Earth and used for different purposes. The **polar satellites** or polar orbit satellites are located in a low orbit (about 800 km) around the planet, surveying Earth's surface from one pole to the other. The periods of their orbits are from one to two hours. This feature allows it to observe the Earth at points that have the same geometry of illumination from the Sun. Each satellite passes through the same observation point over the Earth's surface once every 12 hours, (once during the day and again during the night). The **geostationary satellites** are positioned at a height of approximately 36,000km above the Earth. They rotate around the planet at the same speed as the Earth rotates around its axis, thus remaining stationary over a fixed point on Earth (normally over the Equator line). These satellites are very useful because they see almost one half of the planet, from the same vantage point, thus being ideal for their use in communication and in remote sensing as they can observe the same points on Earth repeatedly. In general, they are capable to supply images at a half-hourly resolution, making possible to observe the cloud movements and mesoscale phenomena such as fronts and hurricanes over the planet with great reliability. These satellites have sensors at various wavelengths ("channels"), allowing the detection of different characteristics of the atmosphere and the surface of the Earth. The field of view of a sensor is narrow, to be able to observe the surface at resolutions better than one kilometer.

Several countries around the world make use of geostationary satellites, so that the whole planet may be observed at all times (Figure 14): 2 US satellites covering the Eastern Pacific and the American continent (GOES-W over the Pacific and GOES-E over the Amazon basin); 2 EU (at 0° latitude, 0° longitude, permitting the observation of the Atlantic ocean, Africa and Europe; another over the Indian ocean); 1 in India (over the Indian and Pacific oceans and India); 1 from Russian Federation (over the Indian ocean); 1 Japanese (over the Eastern Pacific).

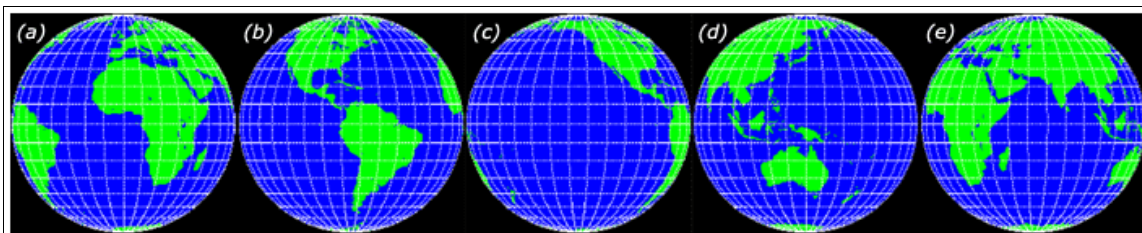

**Figure 14.** Coverage area map of geostationary satellites in operation: (a) METEOSAT; (b) GOES-EAST (GOES-8); (c) GOES-WEST; (d) GMS and (e) IODC.



## The GOES-8

The GOES-8 satellite was launched in April 1994 and is located at longitude 75°W, latitude 0° and altitude of 36,000 km. It weights about 2000 kg, has a total length of 27 m and maintains a fixed position over the Earth through a 3-axis stabilization system. The main body of the satellite has a volume of 8 m<sup>3</sup>. The main purpose of GOES-8 is weather monitoring and forecasting (NASA, 2001b).

The satellite has a scanner camera that supplies images from a small sector to the full extent of the Earth's disk in five different channels. Table 1 describes the features of each channel and Table 2 presents the precision of the navigation data and a record of the images supplied by the satellite. Figure 15 shows two images of GOES-8, the first one obtained from channel 1 (spectral band of the visible) and the second from channel 4 (spectral band of the infrared).

Table 1. Image characteristics of satellite GOES-8

Channel	Wavelength ( m)	Field of View	Sub point resolution
		L/O x N/S (km)	L/O x N/S (km)
1	0,52 - 0,72	1,0 x 1,0	0,57 x 1,0
2	3,78 - 4,03	4,0 x 4,0	2,3 x 4,0
3	6,47 - 7,02	8,0 x 8,0	2,3 x 8,0
4	10,2 – 11,2	4,0 x 4,0	2,3 x 4,0
5	11,5 – 12,5	4,0 x 4,0	2,3 x 4,0

Source: Menzel & Purdom (1994).

Table 2. Navigation confidence and satellite's image recording performance of GOES-8.

Parameter	Midday (±8h)	Midnight (±4h)
Navigation confidence at nadir	4 km	6 km
Registry (in a 25min image)	42r ad (1,5 km)	42r ad (1,5 km)
Registry (in consecutive images)		
15 min	42r ad (1,5 km)	42r ad (1,5 km)
90 min	42r ad (1,5 km)	42r ad (1,5 km)
24 h	42r ad (1,5 km)	42r ad (1,5 km)
48h	42r ad (1,5 km)	42r ad (1,5 km)
Co- registry (between channels)	42r ad (1,5 km)	42r ad (1,5 km)

Source: Menzel & Purdom (1994).

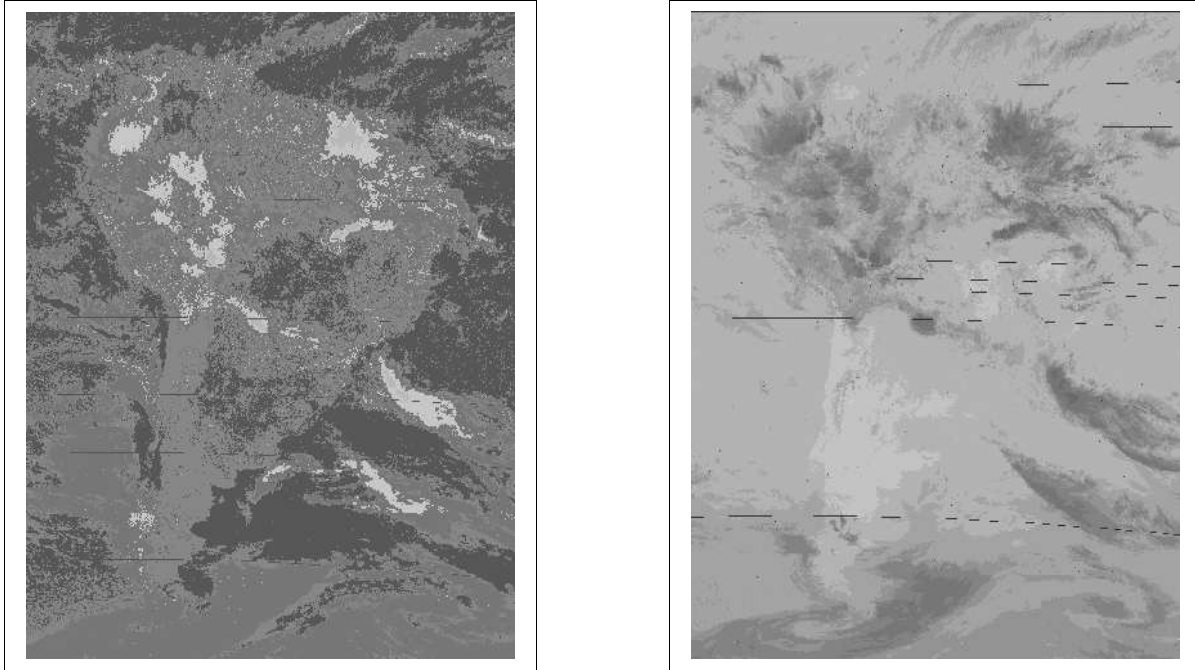

**Figure 15.** Images obtained through GOES-8 on 02/18/1999 at 14h45 UTC: (a) visible channel and (b) infrared channel.

**Table 3.** Features of radiometers of the METEOSAT satellite.

<b>Primary aperture</b>	400 mm diameter		
<b>Secondary aperture</b>	140 mm diameter		
<b>Channel</b>	<b>Visible</b>	<b>Water Vapor</b>	<b>Infrared</b>
<b>Spectral band (<math>\mu\text{m}</math>)</b>	0.45 - 1.0	5.7 - 7.1	10.5 - 12.5
<b>Field of View at sub-satellite point (km)</b>	2.5	5	5
<b>Detector type</b>	Si	HgCdTe	HgCdTe
<b>Focal distance (mm)</b>	3650	535	535
<b># of detectors</b>	2 (2)	1 (1)	1 (1)
<b># of pixel in one line</b>	5000	2500	2500
<b># of lines in a image</b>	5000	2500	2500

### **The METEOSAT**

The imager of the METEOSAT satellite is a high-resolution radiometer satellite with three spectral bands in the visible, the infrared and the water vapor range of the electromagnetic spectrum. Radiation measurements of Earth's complete disk are obtained during a scanning period of 25 minutes. The scanning is followed by a five-minute period for stabilization and adjustment, so that a full set of images of Earth's full disk is available every 30 minutes. Scanning goes from East to West using the rotational movement of the satellite. Scanning

from South to North is accomplished through directional steps of the radiometer's telescope. A sample of a full disk in the visible channel is shown on Figure 16 and a scanning diagram in Figure 17. The main features of the METEOSAT imager are shown on Table 3.

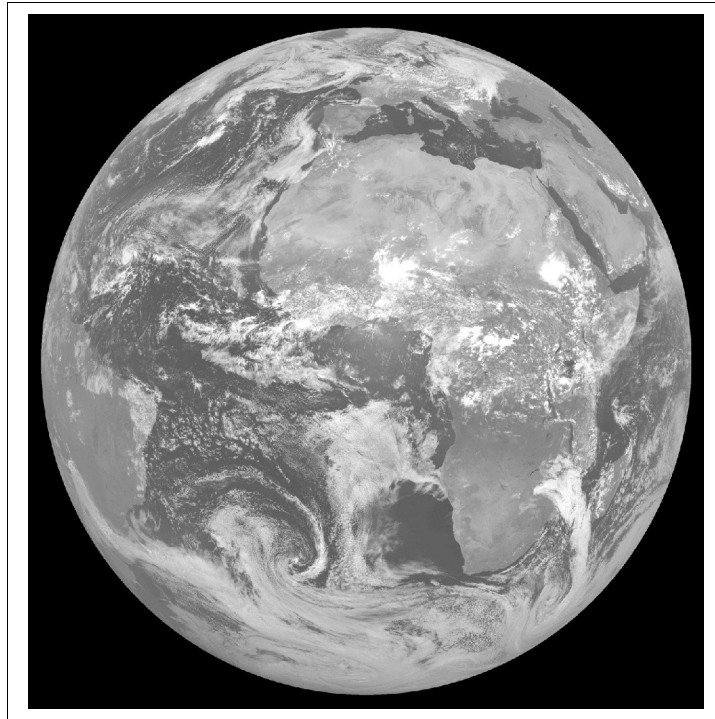

Figure 16. Image of Earth's complete disc obtained from METEOSAT in the visible channel.

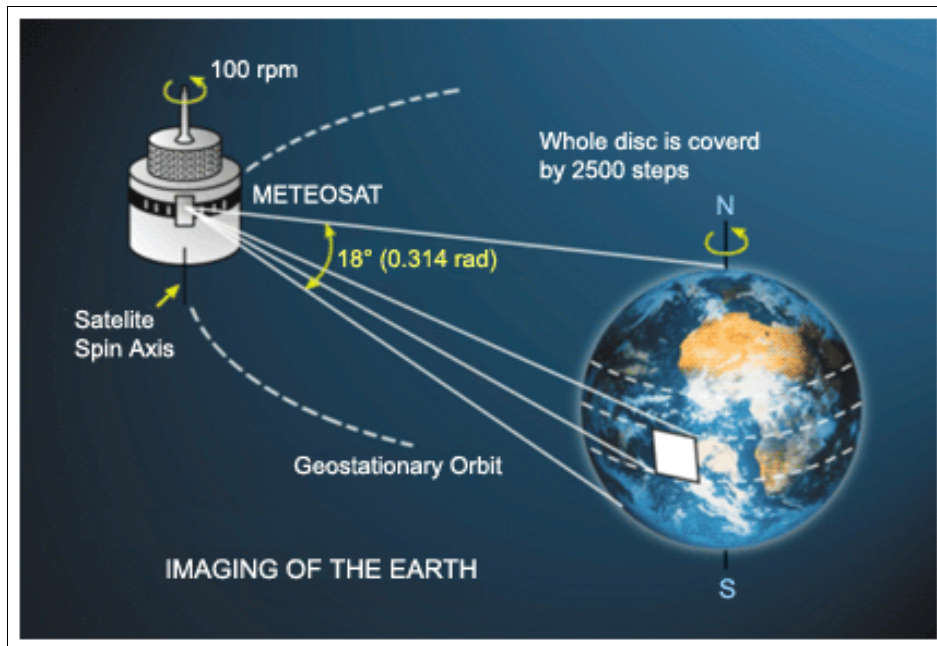

Figure 17. Graphic representation of a scan to obtain the image.

## Radiative Transfer models used in the SWERA Project

### **BRASIL-SR model description**

BRASIL-SR is a physical model to obtain estimates of solar radiation reaching the surface that combines the utilization of the “two-stream” approximation method to solve the radiative transfer equation through the use of certain parameters of statistic nature obtained from satellite images.

The incident solar radiation is estimated in three steps: a) treatment of climactic data and satellite images; b) application of the two-stream method; and c) calculation of global radiation. The climatic database has three components: surface temperature, relative humidity and surface albedo. The temperature and relative humidity data are monthly averages from 30 years (1960 to 1990 period) of measurements at weather stations distributed in the Brazilian territory and operated by INMET (Brazilian Institute of Meteorology). The surface albedo data were provided by DAAC – Langley. The BRASIL-SR uses altitude data provided by the GTOPO database developed by EROS Data Center - USA.

The cloud cover coefficient  $C_{eff}$  used as model input describe two effects caused by the presence of clouds: cloud coverage and spatial variation of optical depth of the clouds. To obtain the  $C_{eff}$ , it is necessary to compose images of clear sky and complete overcast through statistical analysis of images of the period of interest.

The model also assumes the existence of a linear correlation between global surface irradiation and the radiation flow reflected to the top of the atmosphere (Pereira et al., 2000, Colle & Pereira, 1997; Stuhlmann et al., 1990), so that it is possible to write:

$$\Phi_g = \Phi_0 \{ [\tau_{clear} - \tau_{cloud}] \cdot (1 - C_{eff}) + \tau_{cloud} \} \quad (1)$$

where  $\Phi_g$  is the radiation flow reaching the surface,  $\Phi_0$  is the irradiation at the top of the atmosphere,  $\tau_{clear}$  and  $\tau_{cloud}$  are, respectively, the atmospheric transmittances in clear sky and completely overcast. As a result, the determination of global solar radiation incident on the surface may be estimated from two independent components: the first corresponds to a clear sky condition,  $\tau_{clear}$ , and the second to an overcast condition,  $\tau_{cloud}$ . The component  $\tau_{clear}$  is a function of the scattering on the surface, the solar zenithal angle and the optical thickness of the atmospheric constituents. The component  $\tau_{cloud}$  is a function of the solar zenith angle, the optical thickness and altitude of the clouds tops. The random nature of the solar irradiation in any nebulosity condition is included in the model through the cloud cover coefficient. Both components may be estimated from climactic data and parameterizations of well-known physical processes that occur in the atmosphere.

To estimate the transmittance for a given sky condition, the model splits the solar radiation spectrum in 135 intervals and the atmosphere in 30 layers. The interacting processes considered are: clouds, Rayleigh scattering due to atmospheric gases, absorption by atmospheric gases ( $O_3$ ,  $CO_2$  and water vapor), and Mie scattering due to aerosols. The concentration of each constituent as well as the temperature and thickness of each layer of

the atmosphere are established based on the type of atmosphere set up by the air temperature at the surface (input data). The concentration of atmospheric constituents is used to calculate the optical thickness of each radiative process in each atmospheric layer. The study developed by Leckner (1978) was used for the water vapor parameterization. The model adopts the continental aerosols profile described by McClatchey (1972) for altitudes from 0 to 50 km. This aerosol profile is corrected in the first 5 km based on climactic values of visibility established as a function of latitude and the month.

The BRASIL-BR model assumes that: (a) the cloud microphysics is established by the size distribution of droplets of the cloud type being present; (b) the clouds totally attenuate the direct solar radiation coming from the sun and (c) the clouds are vertically and horizontally homogeneous. The model uses the Stephens study (1978) to calculate the coefficient for total extinction and the total content of liquid water in the cloud. The optical thickness of clouds in each atmospheric layer in which they are present is obtained assuming that the total amount of water in the cloud is isotropically distributed.

The component of diffuse radiation is estimated considering the effect of multiple reflections in several atmospheric layers and that the surface albedo is identical for diffuse and direct radiation. After estimating the both transmittances, the expression (1) is used to estimate global solar irradiation on the surface.

### **SUNY-Albany model description**

The State University of New York at Albany developed a model to calculate global irradiance utilizing a statistical method based on a modified Kasten model for clear sky irradiance. The global horizontal irradiance,  $GHI$ , is obtained from the following expression:

$$GHI = (0.02 + 0.98 \cdot (1 - CI)) \cdot G_{clear} \quad (2)$$

where  $G_{clear}$  is the clear sky global irradiance estimated with the modified Kasten model:

$$G_{clear} = 0.84 E_0 \cos(\theta_0) \exp(-0.027m \exp(-z/8000) + \exp(-z/1250)(TL - 1)) \quad (3)$$

where  $E_0$  represents the extraterrestrial solar irradiance,  $\theta_0$  is the solar zenith angle,  $m$  is the air mass,  $z$  represents the ground elevation in meters and  $TL$  is the Linke turbidity obtained from the direct irradiance of clear sky (Kasten, 1980). The direct irradiance of clear sky is obtained as a function of the Rayleigh scattering; the extinction by aerosols; and the absorption by atmospheric gases, water vapor and ozone, using an independent zenith angle of Kasten's formula.

### **DLR model description**

The method for direct normal irradiance developed by DLR uses the model for estimating clear sky irradiance, described by Bird and Iqbal (Iqbal,1983), which parameterize the transmittances for the main atmospheric radiative processes. The cloud contribution to the atmospheric transmittance was included by adding a cloud index obtained from satellite images. The direct normal irradiance,  $DNI$ , is defined as follows:

$$DNI = E_0 \cdot \varepsilon \cdot \tau_R \cdot \tau_{Gas} \cdot \tau_{O_2} \cdot \tau_{WV} \cdot \tau_{Ae} \cdot \tau_{CI} \quad (4)$$

with the extraterrestrial solar irradiance corrected for eccentricity ( $E_0$ ) and the transmittances  $\tau_i$  for Rayleigh's scattering, atmospheric gases (CO<sub>2</sub> and O<sub>2</sub>), ozone (O<sub>3</sub>), water vapor, aerosols and clouds, respectively. This method requires information about the atmospheric concentration of ozone, water vapor and aerosols.

The parameterization equations used for every process mentioned before are presented in Iqbal (1983), except for cloud transmittance which adopts the following expression:

$$\tau_{CI} = \frac{CI - 100}{-100} \quad (5)$$

where the cloud index  $CI$  is calculated using local limits for the infrared channels (IR) and visible ones (VIS) of the METEOSAT satellite. The limits are self-adjustable so that they may represent the daily variation of the properties of the surface. The reference temperature of the surface is described as a function of the time for each pixel:

$$T = a_0 + a_1 (\cos(\chi - a_3 + \sin(a_2) \times \sin(\chi - a_3)) + 0.1 \times \sin(\chi - a_3)) \quad (6)$$

with  $\chi = t/24 \times 2\pi$  where  $t$  represents the UTC time of satellite images (in decimal points). The coefficient  $a_0$  represents the average of daily temperature,  $a_1$ ,  $a_2$  and  $a_3$  are related to the temperature variation throughout the day.

### ***NREL model description***

It is a climatic-based model developed at NREL to obtain global solar irradiance estimates for flat surfaces both horizontal and tilted. The model gives estimates for spectral irradiance in clear sky condition at intervals of 0.3 $\mu$ m to 4 $\mu$ m with a resolution of 10nm. The input data used by the model are: zenithal angle, the water content that may precipitate, the ozone concentration, the atmospheric pressure at the surface, the surface albedo, the atmospheric turbidity and the tilt angle of the surface. The global irradiance on a horizontal surface is estimated from:

$$I = I_{d\lambda} \cos(\theta_0) + I_{s\lambda} \quad (7)$$

where  $I_{d\lambda}$  represents the direct irradiance perpendicular to the surface and  $I_{s\lambda}$  represents the diffuse radiation incident at the horizontal surface. The index  $I$  represents the wavelength because it refers to a spectral model.

The model is based on the method described by Bird for the calculation of direct radiation perpendicular to the surface with a few modifications such as the use of a correction factor for the distance between Sun and Earth, and the use of Leckner's formula for transmittances of water vapor, ozone and other atmospheric gases (Iqbal, 1983). The aerosols transmittance is parameterized using the Angstrom's method.

$$I_{d\lambda} = H_{0\lambda} D \tau_{\gamma\lambda} \tau_{a\lambda} \tau_{wv\lambda} \tau_{o\lambda} \tau_{g\lambda} \cos(\theta_0) \quad (8)$$

The  $H_{0\lambda}$  is the extraterrestrial irradiance at the mean distance between Sun and Earth for the wavelength  $\lambda$ .  $D$  is the correction factor for the distance Sun – Earth,  $\theta_0$  is the solar zenithal angle and  $\tau_{i\lambda}$  represent the transmittance functions for the radiative processes: Rayleigh scattering, scattering and absorption by aerosols; absorption by water vapor; absorption by ozone and absorption, respectively, by  $O_2$  and  $CO_2$  gases.

On horizontal surfaces, the diffuse radiation is divided in three components: (1) Rayleigh's scattering component, (2) scattering component by aerosols and (3) the component that takes into consideration the multiple reflections that occurs between the surface and the atmosphere. Thus, if we consider that Rayleigh scattering and the aerosols scattering are independent, the expressions that follow will be good approximations to estimate the diffuse radiation:

$$\begin{aligned}
 I_{s\lambda} &= I_{sr\lambda} + I_{sa\lambda} + I_{smr\lambda} \\
 I_{sr\lambda} &= H_{0\lambda} D \cos(\theta_0) \tau_{o\lambda} \tau_{g\lambda} \tau_{wv\lambda} \tau_{aa\lambda} (1 - T_{r\lambda}^{0.95}) 0.5 \\
 I_{sa\lambda} &= H_{0\lambda} D \cos(\theta_0) \tau_{o\lambda} \tau_{g\lambda} \tau_{wv\lambda} \tau_{aa\lambda} \tau_{r\lambda}^{1.5} (1 - T_{as\lambda}) F_s C_s \\
 I_{smr\lambda} &= (I_{d\lambda} \cos(\theta_0) + I_{d\lambda} + I_{d\lambda}) r_{s\lambda} r_{g\lambda} C_s / (1 - r_{s\lambda} r_{g\lambda})
 \end{aligned} \tag{9}$$

where:

$$\begin{aligned}
 I_{sa\lambda} &= \tau_{o\lambda} \tau_{wv\lambda} \tau_{aa\lambda} [0.5(1 - \tau_{r\lambda}) + (1 - F_s) T_{r\lambda} (1 - \tau_{as\lambda})] \\
 T_{as\lambda} &= \exp(-\omega_\lambda \tau_{a\lambda} M) \\
 T_{as\lambda} &= \exp(-[1 - \omega_\lambda] \tau_{a\lambda} M) \\
 F_s &= 1 - 0.5 \exp[(AFS + BFS \cos(\theta_0)) \cos(\theta_0)] \\
 AFS &= ALG [1.459 + ALG(0.1595 + ALG 0.4129)] \\
 BFS &= ALG [0.0783 + ALG(-0.3824 + ALG 0.5874)] \\
 ALG &= \ln(1 - \langle \cos(\theta_0) \rangle) \\
 F_s &= 1 - 0.5 \exp[(AFS + BFS/1.8)/1.8] \\
 \omega_\lambda &= \omega_{0.4} \exp\left\{-\omega' [\ln(\lambda/0.4)]^2\right\} \\
 C_s &= \begin{cases} (\lambda + 0.55)^{1.8} & \text{if } \lambda \leq 0.45 \mu\text{m} \\ 1.0 & \text{if } \lambda > 0.45 \mu\text{m} \end{cases}
 \end{aligned}$$

The aerosol single scattering albedo at the wavelength  $\lambda$  is represented by  $\omega_\lambda$ ;  $F_s$  is the scattering fraction produced by aerosols in a frontal direction which is independent of the Sun's position;  $r_{g\lambda}$  is the surface albedo and  $r_{s\lambda}$  is the reflectivity of the atmosphere. The term  $\langle \cos(\theta_0) \rangle$  represents the asymmetry factor of scattering caused by aerosols and  $\omega'$  is the variability factor of the single scattering albedo with the wavelength. For rural aerosols adopted in the model,  $\omega'$  assumes the value of 0.095,  $\omega_{0.4}$  is 0.945 and  $\langle \cos(\theta_0) \rangle$  has a value of 0.65.

It is important to note that the values of the parameters used in the NREL model, as well as the exponents that appear on the expression described in (9), were adopted to tune the model so that the estimates obtained will be in accordance with the results obtained with a very stringent physical model for the resolution of the equation of radiation transfer. The authors of the model observed that the irradiance scattered by aerosols is underestimated for zenithal angles greater than 60°.

For estimating irradiances in tilted surfaces, this model uses the algorithm developed by Hay and Daves to calculate irradiance on tilted surfaces. The algorithm has demonstrated a very good agreement with results supplied by exact computational models in clear sky conditions.

$$\begin{aligned}
 I_{\lambda}(t) = & I_{d\lambda} \cos \theta + \\
 & + I_{s\lambda} \left\{ [I_{d\lambda} \cos \theta / (H_{0\lambda} D \cos(\theta_0))] + 0.5 (1 + \cos t) [1 - I_{d\lambda} / H_{0\lambda} D] \right\} + \\
 & + 0.5 I_{d\lambda} r_{g\lambda} (1 - \cos t)
 \end{aligned}
 \tag{10}$$

where  $t$  is the angle of tilt of the tilted surface (using 0° for a horizontal surface) and  $\theta$  is the incidence angle of the direct beam on the tilted surface. The first term refers to the direct component that reaches the surface. The second term corresponds to the diffuse radiation and the circumsolar component, whereas the last term refers to the isotropic radiation reflected by the surface.

## Procedures for ground data acquisition

The objective of this paper is to geographically and technically characterize a solar measuring station for the purpose of establishing continuously monitoring stations with the most advanced resources available. Each participating station should prepare a report with the proposed survey, keep a copy of it locally and send another one to the document center. The participants shall pay attention to any modifications of the description of the station such as the construction of buildings in the vicinity and/or a decrease or increase in the green area or the urbanization surrounding the station. In case of significant interference the reports will have to be updated immediately.

The data obtained from the stations will be utilized to validate the satellite images, therefore it is necessary to characterize the station. The characterization is done from a general description of the adjoining neighborhood, the topography and the prevailing vegetation close to the station.

Another important item is the knowledge of the average and extreme weather conditions for the station's region. The analysis for validation will be made from these data.

After describing the neighborhood it becomes necessary to describe the existing instruments, their calibration, and the data collecting, storing and handling procedures.

Lastly, the procedures for installing, operating, storing and transmitting data aimed at insuring the quality of the data obtained will be suggested in this report.



## Station Characterization

### General description

In this section, complete information about the institution and the members involved in the project shall be described. After obtaining these basic data a general description of the geographical location represented by the station becomes necessary. Among them are the following:

- Full name of the principal scientist and substitute as well as other staff members involved with the stations with their professional qualifications.
- Name of the research or teaching institution, department, building, laboratory, room, complete address, fax, telephone, e-mail and home page.
- Geographic coordinates, altitude (in relation to mean sea level), height (in relation to the station's ground), and date when measurements started. The use of a GPS to obtain more precise data is recommended.
- A topographic map showing the station's surroundings within an approximately radius of 15km to a scale of 1:250,000. See sample on Figure 18.



Figure 18. Sample of mapogram 8-10 km around the station.

### Description of station's neighborhood and local climate

In this section the intermediate neighborhoods, the topography, the predominating surface finish around the station and the climate shall be described. The items to be specified in a simple and abbreviated form are the following:

- A description of the population centers and their density around the station or the closest one.
- Main sources of pollution. If the station is located in a growing or declining urban area. If the station is subject grass burnings, close to roads or industries with a substantial emission of pollutants.
- Water bodies or significant topographical or weather conditions close to the station. For example: lakes, rivers, seas, bays, mountains, volcanoes, etc.
- A description of the local climate giving mean values and extreme maximum and minimum temperatures for winter and summer, humidity, wind, precipitation and atmospheric pressure. A description significant climactic events occurring in the area such as hurricanes, tornadoes, fires, volcanic eruptions, etc.
- A mapogram (1-2km) or aerial photo of the region to a scale of 1:50,000 showing the main access roads, buildings and green areas in the vicinity. See sample in Figure 19.

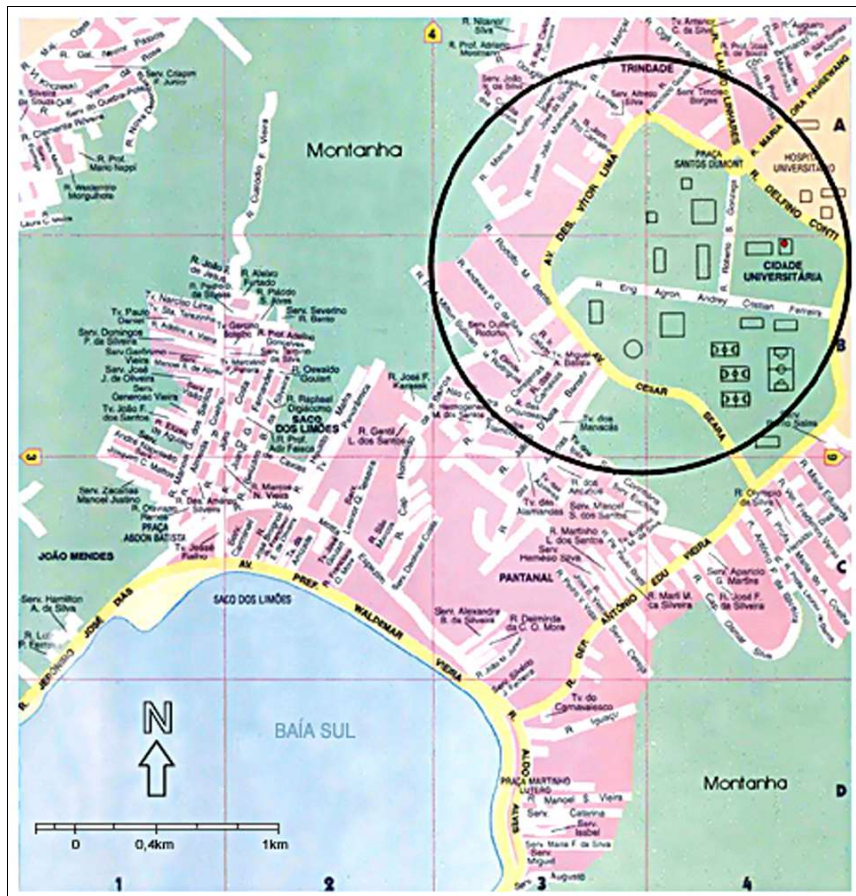

Figure 19. Sample of mapogram of the vicinity of station 1-2 km.

- The topographical classification of the station's region in accordance with the types contained in the following chart.

Data in relation topography type		
Value	Topographic Feature	Population Density
1	Flat	Urban
2	Flat	Rural
3	Hilly	Urban
4	Hilly	Rural
5	Mountain top	Urban
6	Mountain top	Rural
7	Mountain Valley	Urban
8	Mountain Valley	Rural

- The classification of the region's surface in accordance with the types contained in the following chart.

Data in relation surface type		
Value	Major surface type	Descriptor
1	Glacier	accumulation area
2	Glacier	ablation area
3	Iceshelf	-
4	Sea ice	-
5	Water	river
6	Water	ocean
7	Water	lake
8	Desert	rock
9	Desert	sand
10	Desert	gravel
11	Concrete	-
12	Asphalt	-
13	Cultivated	-
14	Tundra	-
15	Grass	-
16	Shrub	-
17	Forest	evergreen
18	Forest	deciduous
19	Forest	mixed
20	Rock	-
21	Sand	-

- Photographs of the station showing the general location of sensors and the visualization of the cardinal points, more or less as in the following samples.



Sample of Northern face.



Sample of Eastern face.



Sample of Western face.



Sample of Southern face.

### Technical description of the station

In this section the quantity and type of instruments used to acquire data shall be described. This description is important to define the type of sensor, the precision and wear to be expected over a long period of measurement. The objective is to assess the general status of the sensors and the instruments being used. The items to be listed are as follows:

## Sensors

To determine the type and the accessories being currently used (fans, level indicators, drying agents, etc.). Brand name, model, type of sensor and its precision. Spectral response, sensor calibration certificates, follow-up of life cycle and wear. Date of purchase or beginning of operation. There is a great variety of sensors on the market. Therefore it is important to know their spectral response and their angular sensitivity with regards to the sun. To illustrate such variety, check the spectral response of some types of sensors illustrated on Figures 20 and 21.

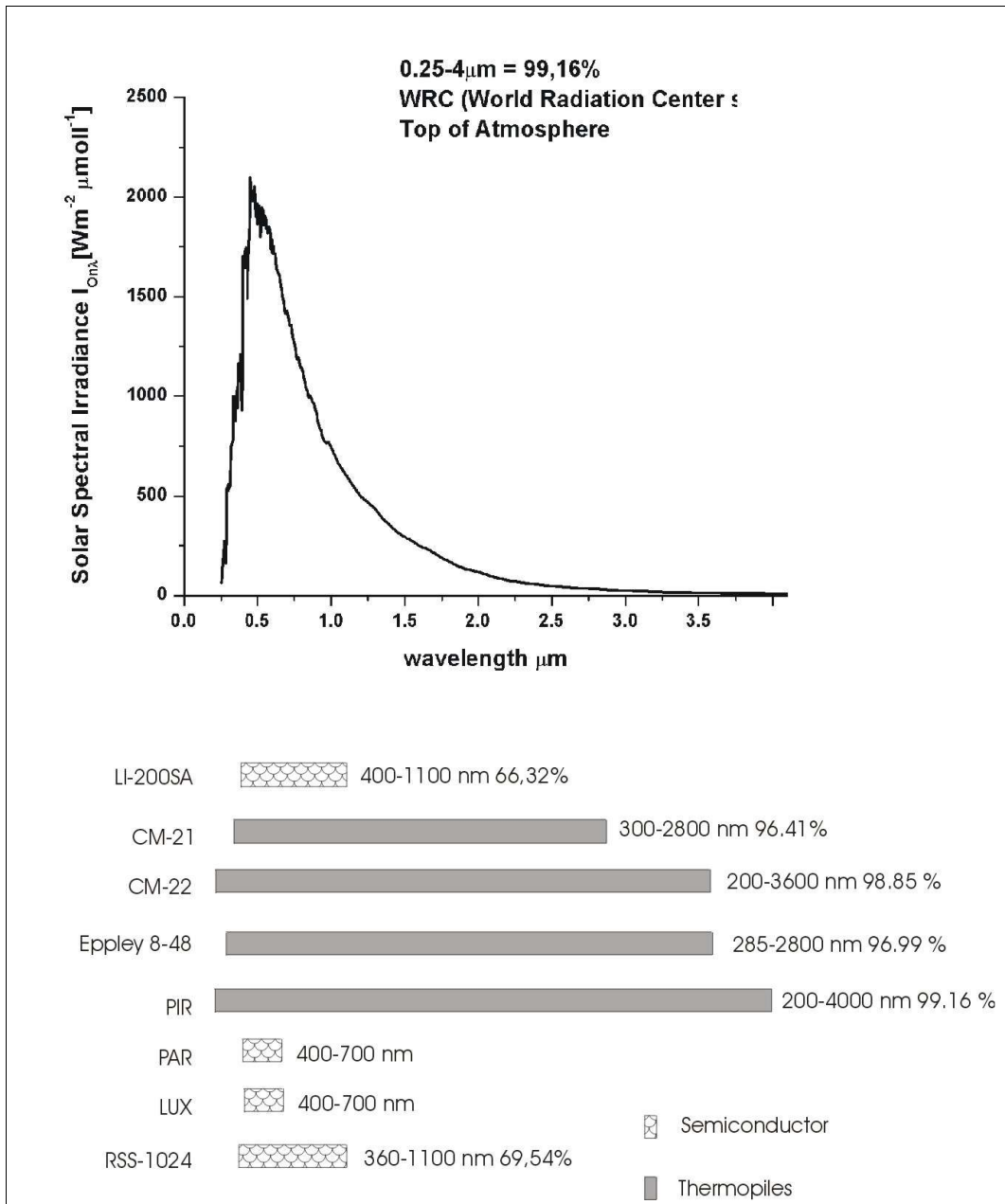

**Figure 20.** Sample of spectral response of some sensors on the market.

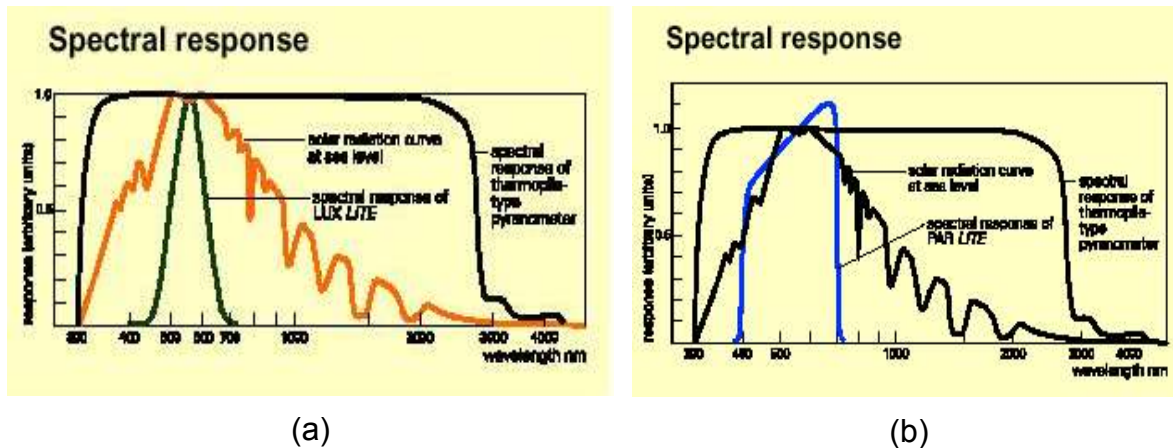

**Figure 21.** Comparative spectral response and linearity of different sensors in regards to the sun. (a) LUX Sensor and thermopile (b) PAR Sensor and thermopile.

### *Data acquisition system*

In addition to listing the sensors installed in a station it is also necessary to describe the data acquisition system. It should indicate the brand name, model, precision, data collecting time and calculated averages. Follow-up of calibration, life time and wear (in case multiplexers with relays are being utilized). Date of purchase or measurement start-up.

### *Documentation about the installation*

A brief description with a sketch indicating the arrangement and orientation of the sensors, the existence of stabilizers, the general status of NO BREAK connecting wires. If a good grounding system exists for the electric supply or not, and lightning protection as well as shielding of equipment. The type of grounding utilized for the sensors, the status of cables and connections of the sensors. It is also necessary to know if a surge protector exists for sensors or telephone lines when these are connected to the data acquisition side computers.

### *Schematic drawings and diagrams*

The documentation shall include an overall scheme and a detailed scheme of the station showing all existing connections. See samples on Figures 22 and 23.

### *Computers for data acquisition and storage*

A brief description of how data are collected in the data logger shall be available. Safety copies of all programs utilized by the station and BACKUP data shall be kept. It is important to note that the inner clock of the computer or the data acquisition system shall be set for GMT, precisely. The clocks of computers (PCs) may vary  $\pm 5$  sec/day. Because of this there needs to be a precise way of adjusting their time. There are automatic time setting programs available through the Internet, which help to do this.

### Operation and data collecting

The operation of a station basically consists of a periodic inspection, the cleaning of the dome sensors and the alignment of shading systems if installed. The deterioration of the sensor surface, the leveling, the drying agent (silica gel), the fan operation, etc., shall also be checked. It is worth noting that the presence of bugs, bird droppings, spider webs, ants, mice, etc., may also bring undesirable consequences and may cause damage to the system.

To organize the daily routine, it is recommended to fill out a report like the sample shown in Attachment 1. The transmission of data to the collecting center and its storage shall be made in an organized fashion. Problems caused by lightning, theft, damage due to natural causes, operational problems of various sorts, etc., shall also be reported.

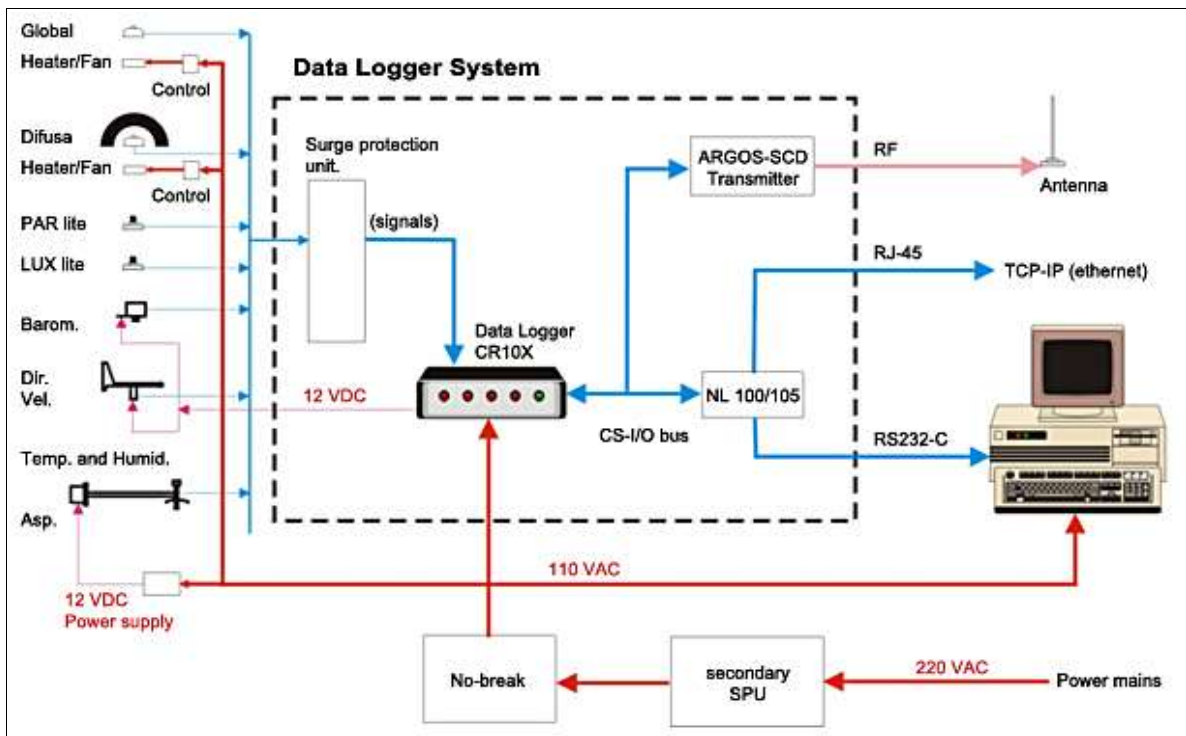

Figure 22. Sample of a general station scheme.

### Data validation

Validation is a quality control performed with the data to verify if they are good, free of noise, operational errors or unnatural interference.

A major difficulty with this verification occurs when one faces erroneous data within valid limits. Some are impossible to be automatically diagnosed unless clearly described by the operator or gleaned from the daily reports. The physical variables obtained for automatic qualification are derived from medium and extreme local meteorological variables supplied with the station's description. The data is classified as normal, when physically possible for the local environment or erroneous. Cross-referencing is also done between sensors and/or possible physical limits for the area. Each station has its own peculiarities and the validation procedures have to be individualized.



## Managing the collected data

The storing of data shall be made with reliable medium. Rigid computer discs are susceptible to damage by fluctuations of the power supply and to viruses when connected to the Internet. Common damage may also come through invasions by unauthorized people or hackers through inappropriate use of the equipment. Therefore it is recommended to be very careful not to share files or equipment via the net. Antiviral usage is recommended. Generally there are good anti virus software available through the Internet and some are free. A periodic update of the antiviral software is recommended.

CD-ROMs, magnetic tapes and diskettes have a useful life limited to a few years. Optic/magnetic disks have high reliability and durability (up to 100 years), but are very expensive. Proper storage of duplicated diskettes, CD-ROMs, etc., in fireproof magnetically shielded closets in air conditioned space is also recommended.

Avoid handling/editing files that do not have a back-up. Always make a copy and store files in a safe place before making any changes.

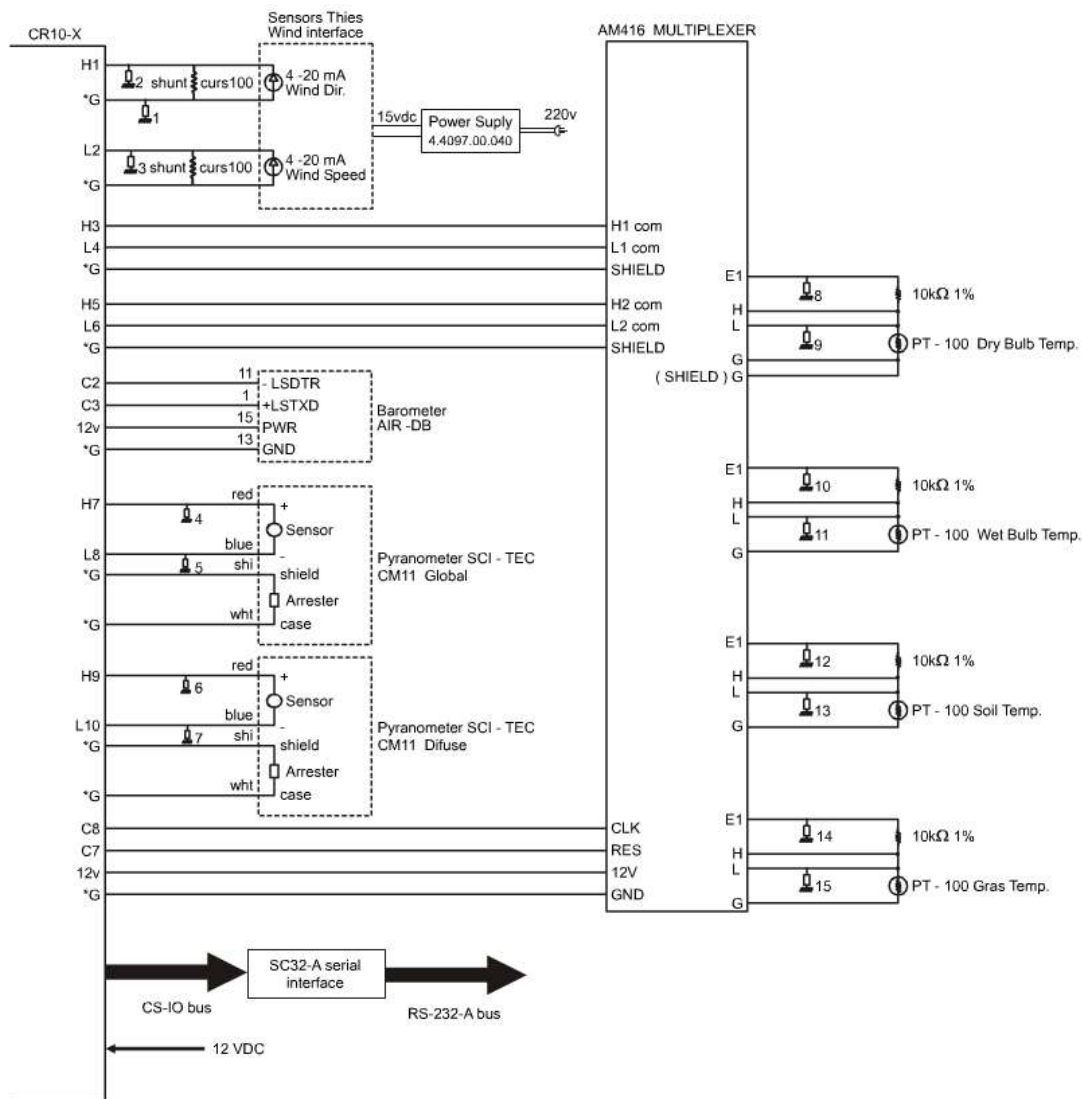

Figure 23. Sample of detailed electronic diagram of station.

## Recommendations for station installation

In this section, a series of recommendations for station installation will be presented. To install a good station just selecting good equipment does not suffice. It is also necessary to choose a good location without external interference with an adequate infrastructure.

### *Choosing a place to install the sensors*

The buildings, nearby, vegetation and the visitors should not interfere with or block the measurements. Reflections of shiny surfaces such as roofs, light poles, white buildings or buildings with glass façades, etc., in line with the sensor's sight line should be avoided. Generally, building roofs are good locations or the ground itself, if it is on a high place. If placed on the ground, on a high place, the station should be away from any obstacle for at least 12 times the equivalent of the nearest obstacle's height. Obstacles are buildings, trees, walls, etc. Shadows of lightning arresters, light poles, antennae and substantial obstructions to the South of the stations (when above the Equator) and to the North (when below the Equator) shall also be avoided. The sensors shall be installed at such a height above the floor as needed to allow for operators and visitors to freely circulate within the area without interfering with the measurements (immediately below the sensors).

The sensors shall be affixed to places with good mechanical stability and which are leveled. They should not be affixed to wooden supports because these may warp with climactic changes. Protective measures against vandalism and depredation through fences and gates shall also be adopted. But these should not hamper the access of operators to the station.

### *Lightning protection*

Verify the presence of lightning poles or towers (Franklin or Faraday type) in the vicinity of sensors and cables. Also insure that the lightning poles and their cables do not affect the sensors.

It is recommended to utilize surge arresters for the sensor's signals, when necessary. The installation, cables and grounding shall avoid the coupling effects of electric discharges of lightnings through ground loops and avoid alternate paths for electric discharges. See Figure 24.

As the case may be, it may be necessary to utilize surge protection in telephone networks whenever they are connected to the computers acquiring the data. Sometimes it is appropriate to electrically insulate the sensors as illustrated in Figure 25. Carry out proper grounding of the equipment, the data logger and the sensors.

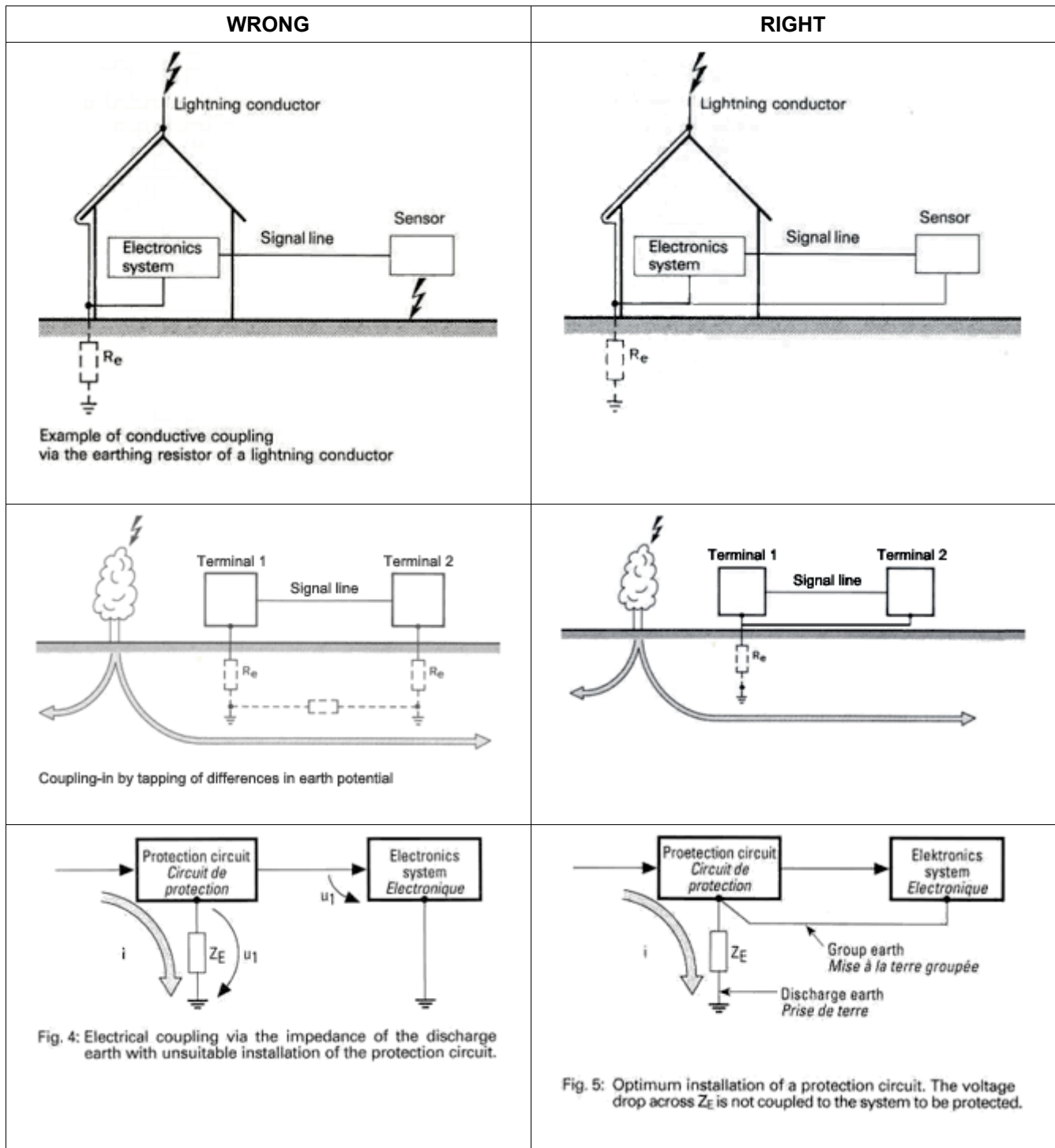

**Figure 24.** Problems related to electric coupling and possible solutions. SOURCE: Adapted from "Lightning Protection for Electronic Equipment and Installations" Meteolabor AG June 1997.

### *Electric mains*

The electric power supply for the station and the installation of the equipment shall be separated from large machinery, induction motors, pumps and air conditioners. It is recommended to use no-breaks or stabilizers for the equipment. It is also recommended to use protection against power surges and a good quality grounding (<10 OHMS). Computer hard discs are very sensitive to variations in the electric power supply. Voltage variations may also cause damage to the instrumentation and sensors.

### *Cables and connections*

Appropriate shielded cables (22 AWG minimum), moisture and waterproof, and resistant to ultra-violet rays shall always be used. Sealed cable crimpers shall also be used too. In case of existing installations, verify the cable deterioration caused by ultra-violet rays, which may leave them brittle or cracked. Also verify corrosion and humidity on connections and splices. Splices shall be soldered and sealed. See sample on Figures 25 (a) and (b). Separate the signal cables from electric cables to minimize interference and noise, even on throughout the walls.

### *Computer Files*

Once collected, the data shall be carefully stored. The back-up files shall be duplicated and stored in different places. The same shall be done with the signal acquisition program. Time base for data loggers and computers should be GMT. Personal Computer clocks precision could vary up to 5 seconds a day. It is important to use a better time base. To solve that it could be used automatic clock setting programs via Internet or to set the computer clock every day to a reliable time source. Data loggers also have the same clock precision problem. They should be corrected frequently. Digital wristwatches usually deviate about 15 seconds per month. Another reliable time source is the cell phones displaying good time references with real time clocks.



(a) Good and bad examples of cable crimping use



(b) Cable deterioration

**Figure 25.** Care and deterioration of sensor cables and connections.

### *Closing Remarks*

Reliable and well-installed monitoring stations generally require little attention and care. When required, the fixes shall be quick and intensive.

It is important to always strive for continuity of data sequence with the least of possible interruptions.

Routine verification and preventive station maintenance associated with equipment and installation reliability reduce the periods of shutdowns.

Monitoring stations are subject to systematic errors. The effects of some problems are only perceived during the data validation. In this case they should be corrected.

Bad data is disposed of causing a waste of money, operator's time, and data treatment preventing the storage of information that will never again be recovered.

Good data produce reliable information, good for many years and bring a return on the investment and work satisfaction to the people involved. They are a very important contribution to the climate variation studies over the years.

## References

- Abreu, S. L. e Colle, S.; “Mapas de otimização de sistemas de aquecimento solar utilizando dados de irradiação estimados por satélite”; NUTAU 2000 - X Congresso Ibérico e V Congresso Iberoamericano de Energia Solar, São Paulo, August, 2000.
- Abreu, S. L., Colle, S., Glitz, K. L. Z. and Rütther, R., “Isolated Hybrid PV-DIESEL Power Plants Design Method”, ECOS2002, Berlin, Alemanha, 2002.
- Blumthaler, M. Solar UV measurements In: Tevini, M. ed. *UV-B radiation and ozone depletion. Effects on humans, animals, plants, microorganisms, and materials*. Florida, Lewis, 1993. p. 71-94.
- Colle, S. e Pereira, E. B., “**Atlas Irradiação Solar do Brasil**”, Instituto Nacional de Meteorologia – INMET, Brasília – DF, October, 1998.
- Cooper, K. D.; Oberthelmann, L.; LeVee, G.; Baadsgaard, O.; Koren, H. Effect of UV light on induction of immune response to epicutaneous antigen in humans. *FASEB J*, 5, A967, 1992.
- Coulson, K.L. *Solar and Terrestrial Radiation: Methods and Measurements*. New York, Academic, 1975. 322 p.
- Dave, J. V.; Canosa, Z. **A direct solution of the radiative transfer equation: application to atmospheric models with arbitrary vertical non-homogeneities**. *Journal of Atmospheric Science*, 31,1089-1101, 1974.
- De Favo, E.C.; Noonan, F.P.; Frederick, J. Biologically effective doses of sunlight for immune suppression at various latitudes and their relationship to changes in stratospheric ozone. *J. Photochem. Photobiol.*, 52(4): 811 - 817, 1990.
- Diekmann, F. J.; Happ, S.; Rieland, M.; Köln, Benesch, W.; Offenbach, Czeplak, G.; Kasten F. **An operational estimate of global solar irradiance at ground level from METEOSAT data: results from 1985 to 1987**. *Meteorol. Rdsch.*, 41, 65-79, 1988.
- Gambi, W. **Avaliação de um modelo físico estimador de irradiância solar baseado em satélites geoestacionários**. MsC dissertation. Universidade Federal de Santa Catarina. Florianópolis, 1998.
- Gautier, C.; Diak, G.; Masse, S. **A simple physical model to estimate incident solar radiation at the surface from GOES satellite data**. *Journal of Applied Meteorology*, 19, 1005-1012, 1980.
- Hanson, K. J. **Studies of cloud and satellite parameterization of solar radiation at the Earth’s surface**. *Proceedings of Miami Conference on Remote Sensing*. Washington: U. S. Department of commerce, 133-148, 1971.

- Harrison, E. F.; Minnis, P.; Barkstrom, B. R.; Gibson, G. G. Radiation budget at the top of atmosphere. In: Gurney, R. J.; Foster, J. L.; Parkinson, C. L. (ed.) **Atlas Of satellite observations related to global change**. San Diego: Cambridge University Press, 1993. Chap. 2, p. 19-38.
- Hay, J. E.; Hanson, K. J. **A satellite-based methodology for determining solar irradiance at the ocean surface during GATE**. Bulletin American Meteorological Society, 59, 1549, 1978.
- Huffman, R.E. *Atmospheric ultraviolet remote sensing*. San Diego, Academic, 1992. 320p.
- Iqbal, M. **An introduction to solar radiation**. Ontario: Academic Press, 1983.
- Kerschgens, M.; Pilz, U.; Raschke, E. **A modified two-stream approximation for computations of the solar radiation budget in a cloudy atmosphere**. Tellus, 30, 429-435, 1978.
- Kondratyev, K. Ya. **Radiation in the atmosphere**. New York: Academic Press, 1969.
- Leckner, B. **The spectral distribution of solar radiation at the Earth's surface – elements of a model**. Solar Energy, 20, 2, 143-150, 1978.
- Lenoble, J. **Radiative transfer in scattering and absorbing atmospheres: standard computational procedures**. Virginia: A. Deepak Publishing, 1985.
- Madronich, S. UV radiation in the natural and perturbed atmosphere. In: Tevini, M. ed. *UV-B radiation and ozone depletion :Effects on humans, animals, plants, microorganisms, and materials*. Florida, Lewis, 1993, p. 17-69.
- Martins, F. R. **Influência do processo de determinação da cobertura de nuvens e dos aerossóis de queimada no modelo físico de radiação BRASIL-SR**. PhD Thesis at INPE (Instituto Nacional de Pesquisas Espaciais). São José dos Campos, August, 2001.
- McClatchey, R. A.; Fenn, R. W.; Selby, J. E. A.; Volz, F. E.; Garin, J. S. **Optical properties of atmosphere**. Bedford, Massachusetts: Air Force Cambridge Research Laboratories, (AFCRL-72-0497), 108p, 1972.
- McKenzie, R.L.; Matthews, W.A.; Johnston, P.V. The relationship between erythemal UV and ozone, derived from spectral irradiance measurements. *Geophys. Res. Lett.*, 18(12):2269-2272, 1991.
- Menzel, W. P.; Purdom, J. F. W. **Introducing GOES-I: The first of a new generation of geostationary operational environmental satellites**. Bulletin of American Meteorological Society, 75, 5, 757-781. May 1994.

National Aerospace Agency. **GOES project homepage**. [Online] <<http://goes2.gsfc.nasa.gov>>. February 2001.

National Aerospace Agency. **GOES project science**. [Online] <<http://rsd.gsfc.nasa.gov/goes>>. February 2001.

Pereira, E. B.; Colle, S. **A energia que vem do Sol**. Revista Ciência Hoje, 22, 130, 25-35, 1997.

Pereira, E. B.; Martins, F. R.; Abreu, S. L.; Couto, P.; Stuhlmann, R.; Colle, S. **Effects of burning of biomass on satellite estimations of solar irradiation in Brazil**. Solar Energy, 68, 1, 91-107. January 2000.

Roy, C.R.; Gies, H.P.; Tomlinson, D.W.; Lugg, D.L. Effects of ozone depletion on the ultraviolet radiation environment at the Australian stations in Antarctica. *Antarctic Research Series*, 62:1-15, 1994.

Rüther, R., Martins, D. C. and Bazzo, E., "Hybrid diesel / photovoltaic systems without storage for isolated mini-grids in northern Brazil", Proc. of the 28th IEEE Photovoltaic Specialists Conference, Anchorage, Alaska, 18-22 September 2000, pp. 1567-1570.

Tevini, M. Molecular Biological Effects of Ultraviolet Radiation. In: Tevini, M. ed. *UV-B radiation and ozone depletion: Effects on humans, animals, plants, microorganisms, and materials*. Florida, Lewis, 1993. p.1-15.



# Appendix 1 example of a daily station report.

remarks: The structure of this report depends on the type and quantity of sensors available in each station

## Solar Station < station's name > Daily Report

- : OK
- X: Problems

	Global	Direct	Diffuse (disk)	Diffuse (ring)	Long Wave	TBU-TBS	CCD	Photometer
alignment								
leveling								
dehydration ventilators								
cleaning								
temperature								

### Sinoptic Observation:

---



---

### General Observation:

---



---



---



---



---



---

GMT

05:45,

06:00,

06:15

08:45,

09:00,

09:15

11:45,

12:00,

12:15

Operator: \_\_\_\_\_ Date \_\_\_ / \_\_\_ / \_\_\_\_\_ Time \_\_\_\_:\_\_\_\_

## **Appendix 2 questionnaire to select stations to supply data**

Send to: Enio Bueno Pereira  
Instituto Nacional de Pesquisas Espaciais – CEA/DGE  
SWERA Regional Agency for Latin America  
Av. dos Astronautas, 1758, C.P. 515  
12201-970 S. J. Campos, SP - BRASIL

### **Objectives**

Quality data concerning climate, meteorology, solar radiation and winds will be required to implement and validate models for solar and wind energy resource assessment. With this objective in mind we are sending this questionnaire for preliminary evaluation of possible station candidates requesting them to supply us with data for the project in their country.

The steps of the process for candidate station selection will be as follows:

1. Procedure for obtaining data files to be used by SWERA - Questionnaires of pre-evaluation will be sent to those in charge of stations,
2. Analysis of questionnaires and selection of possible candidate stations,
3. Visits to candidate stations, as necessary, or requesting additional information to better describe the station,
4. Final selection of stations,
5. Installation of surface mounted database.

If necessary, collaborating countries may have their radiation measuring sensors calibrated in accordance with WMO standards, only being billed for the costs of transportation of the equipment.

## **QUESTIONNAIRE**

*(Please try to be as objective as possible and insert any applicable commentaries – use extra sheets of paper, as necessary).*

### ***Climatology***

**Existing data base** (historical series with more than 30 years)

Are there any climactic databases of the region?

What are the variables of the database?

How is data stored?

Is the database available for SWERA? How?

***Meteorology*** (Use one questionnaire per station)

**General Data on data collecting station** (active stations collecting data regularly)

Name/contact of person in charge

Institution

City/Country

Latitude

Longitude

Altitude

Obstructions on the horizon (mention type of obstruction for every 10 degrees of the horizontal azimuth)

Type of area (urban, forest, desert, etc.)

Indicate possibility of sending photos of horizon around the station and of the station itself)

### **Solar Radiation Data**

Models of sensors used

Type of sensor (thermal cell, silicon, hours of insolation)

Frequency of maintenance and calibration and date of last check

Components of solar radiation measured (global, direct, diffuse, etc.)

Availability of surface diffusion measurements

Form in which data is stored (type of medium)

Frequency of sampling, recording and integration of data

Qualification performed on data

Procedure for obtaining data files to be used by SWERA

## **Wind Data**

Type and models of sensors used  
Height of each sensor  
Dates of calibration and/or replacement  
Form in which data is stored (type of medium)  
Frequency of sampling and integration of measured data  
Qualification performed on data  
Procedure for obtaining data files to be used by SWERA

## **Other meteorological variables measured**

Meteorological variable (one for each variable, ex.: pressure, precipitation, relative humidity, visibility, albedo, radiosounding data, etc.)  
Models of sensors used  
Type of sensor  
Frequency of maintenance and calibration and date of last check  
Form in which data is stored (type of medium)  
Frequency of sampling and integration of measured data  
Qualification performed on data  
Procedure for obtaining data files to be used by SWERA